

GYROSTAFF ARRA/LONG

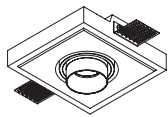

PROTRUDING

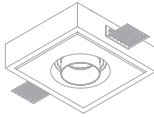

FLUSH



ADJUSTABLE INDOOR RECESSED LIGHTING RANGE

The GYROSTAFF low-luminance recessed spotlight is equipped with an ARRA LED module offering a wide range of colour temperatures, IRCs and optics. As a result, this product offers maximum visual comfort, while diffusing excellent quality of light. It can be adjusted, allowing a pivot of 32° and a rotation of 360°.

The GYROSTAFF ARRA will surprise you with its discreet ceiling mounting and ease of installation thanks to its fixing brackets.

An excellent product offering a host of advantages, especially for confined spaces with limited ceiling height.

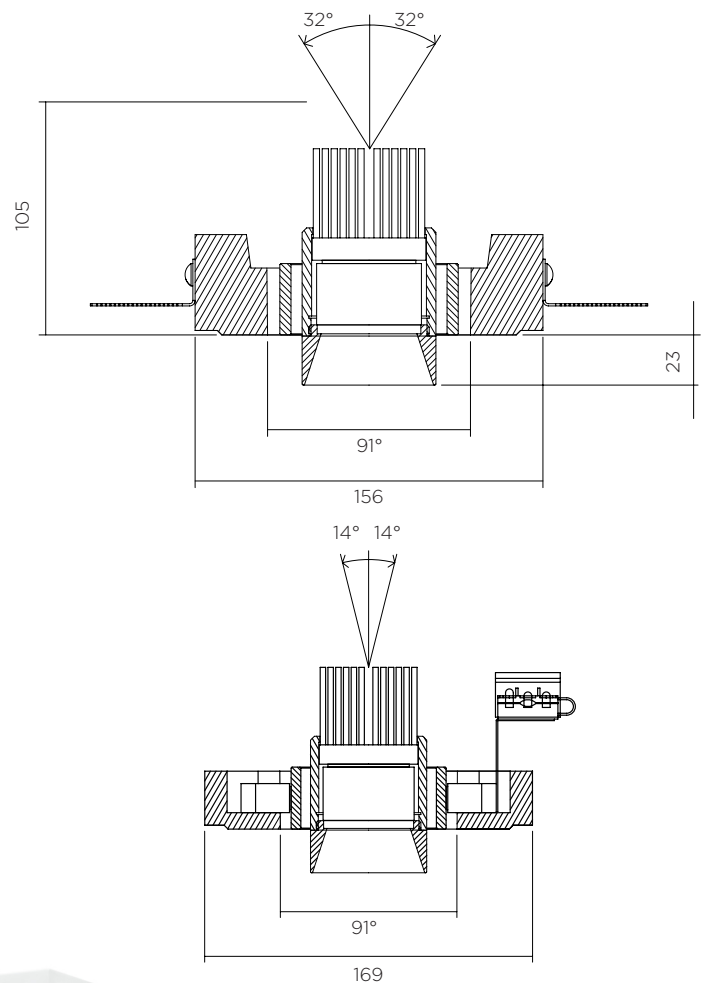

FEATURES

- Discreet
- Easy installation
- Anti-glare
- Beam: from 7° to 35°
- Colour temperature: 2700° K, 3000° K, 3500° K, 4000° K
- Safety cable
- Finish: epoxy paint

OPTIONS

- RGBW
- Tunable white
- Other colour temperatures
- Other beams
- Other colours (*custom RAL*)
- UL junction box

ACCESSORIES

- Elliptical filters
- Honeycomb grille

CONTROL*

- 0-10V
- DMX
- DALI
- Wireless

*According to driver choice



IN THE SAME RANGE
GYROSTAFF ARRA/SHORT FLUSH CONE

GYROSTAFF **ARRA**/LONG



POWER* AND PHOTOMETRY

INDICATIVE DATA FOR LED 3000° K IRC>90

LED type	Voltage	Max direct current	Power	Beams	Candelas in the axis	Lumens output
LED 2	12 VDC	900 mA	10.7 W	7°	34,925 Cds	776 Lms
LED 2B	12 VDC	900 mA	10.4 W	12°	19 590 Cds	994 Lms
				25°	3 796 Cds	740 Lms
				34°	1 987 Cds	545 Lms



Connection to a direct current driver (to be ordered separately).

Devices must be connected to the driver before switching them on.
Failure to respect this requirement will damage the devices irreversibly.

*Data may change according to developments in LED technology